

オイルレススライドプレート

銅系粉末焼結タイプ
板厚20mm

SO#220



SOX



●W=28~75

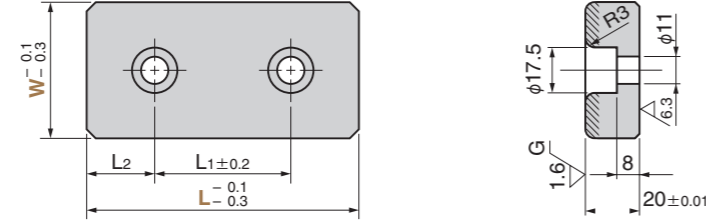

●W=48、L=250
●W=75、L=250

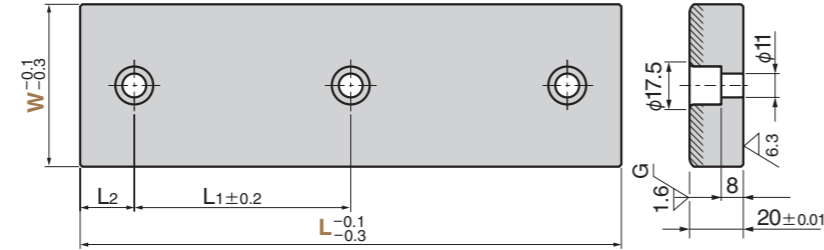

●W=100以上

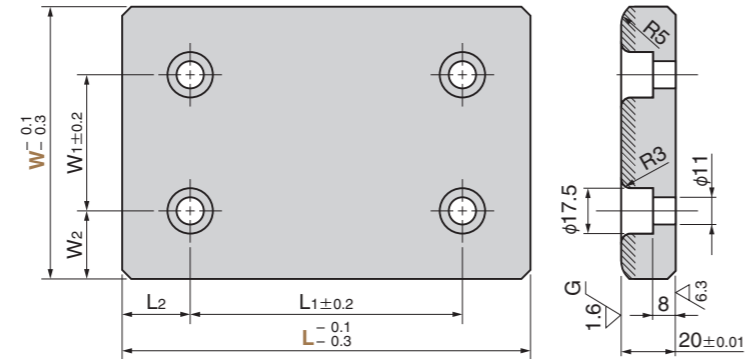

SOXT (2穴タイプ)

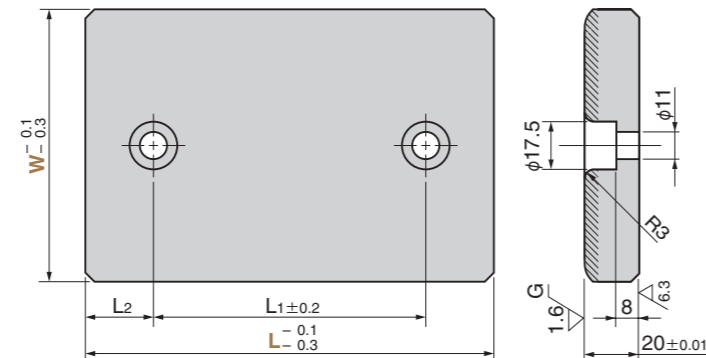

●スライド方向



●W=28

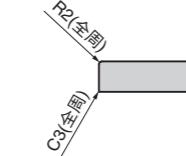

●W=38~58

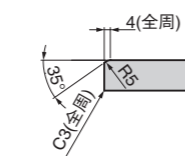

●W=75以上

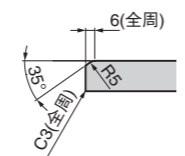

材質 銅系粉末焼結 (SO#220)
///// 部焼結層
厚さ1.2mm 以上
SS400 (ベースプレート)

| W1 | W2 | L1 | L2 | Catalog No. | W | L | |
|-----|------|-----|----|-------------|-----|-----|------|
| | | | | | | SOX | SOXT |
| | | 45 | 15 | | | 75 | |
| | | 50 | 25 | | 28 | 100 | |
| | | 100 | | | | 150 | |
| | | 45 | 15 | | | 75 | |
| | | 50 | | | 38 | 100 | |
| | | 75 | 25 | | | 125 | |
| | | 100 | | | | 150 | |
| | | 45 | 15 | | | 75 | |
| | | 50 | | | 48 | 100 | |
| | | 75 | 25 | | | 125 | |
| | | 100 | | | | 150 | |
| | | 100 | 50 | SOX | | 200 | |
| | | | 25 | | | 250 | |
| | | 45 | 15 | | | 75 | |
| | | 50 | | | 58 | 100 | |
| | | 100 | | | | 150 | |
| | | 25 | | | | 75 | |
| | | 50 | | | | 100 | |
| | | 75 | | | 75 | 125 | |
| | | 100 | | | | 150 | |
| | | 150 | 25 | | | 200 | |
| | | 100 | | | | 250 | |
| | | 50 | | | | 100 | 100 |
| | | 75 | | | | 125 | 125 |
| 50 | 25 | 100 | | | 100 | 150 | 150 |
| | | 150 | | | | 200 | 200 |
| | | 200 | | | | 250 | 250 |
| | | | 50 | | | 300 | 300 |
| | | 75 | | SOX | | 125 | 125 |
| | | 100 | | SOXT | | 150 | 150 |
| 50 | 37.5 | 150 | 25 | | 125 | 200 | 200 |
| | | 200 | | | | 250 | 250 |
| | | | 50 | | | 300 | |
| | | 100 | | | | 150 | 150 |
| 100 | 25 | 150 | 25 | | 150 | 200 | 200 |
| | | 200 | | | | 250 | 250 |

W1・W2はSOX (W = 100以上) のみの寸法です。



Order

| Catalog No. | W | L |
|-------------|-----|-----|
| SOX | 28 | 75 |
| SOXT | 100 | 100 |

■ 使用範囲

| 給油条件 | 環境条件 | 許容最高面圧 P N/mm ² | 許容最高速度 V m/min | 許容最高 PV値 N/mm ² ・m/min | 使用温度範囲 °C |
|----------|------|-------------------------------|-------------------|--------------------------------------|--------------|
| 無給油 | 大気中 | 50 | 30 | 100 | -40 ~ +120 |
| 定期給油 (脂) | | 75 | 60 | 150 | |

■ 物性

| 比重 | 硬さ HRM | 圧縮強度 N/mm ² (0.2%耐力) | 含油率 % |
|---------|-----------|------------------------------------|----------|
| 6.2±0.3 | 70 ~ 90 | 200 ~ 250 | 18 以上 |

■ 特注品のご相談・ご注文も承ります。