

ルーズコア用 傾斜ピン インロー・雌ねじタイプ

INCLINED PIN FOR LOOSE CORE

KOPB

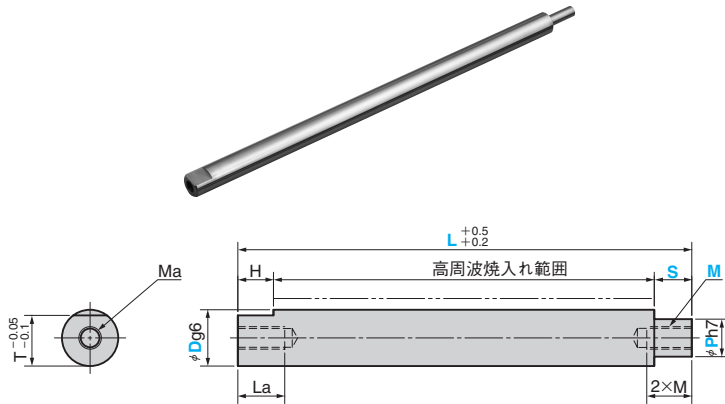

KOPBS (回り止め2面タイプ)

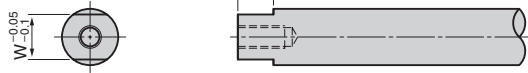

KOPNB (回り止め加工無し)

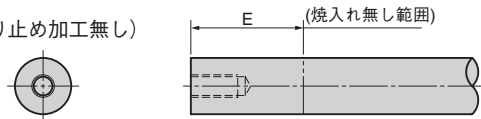

材質 SUJ2
---一部高周波焼入れ
(HRC58以上)
深さ0.8~2.0mm

D g6	T	H	Ma×La	W	E
16 -0.006 -0.017	13	14	M8×20	10	30
20	17	17	M10×25	14	40
25 -0.007 -0.020	22	18		19	50
30	27	19	M12×25	24	
35 -0.009 -0.025	31	19		27	60
40	36	20	M16×35	32	

Catalog No.	D	L 指定1mm単位	S 指定1mm単位	P 選択	M 選択	G (KOPBSのみ)
	16			10	6	
				11 12	6 8	
				13	8 10	
	20			10	6	
				11 12 13	6 8	
				15 16	8 10	
KOPB KOPBS KOPNB	25	100~1000	P≤S≤(P×4) L-H-S≥10	12 13	6 8	H≤G≤E (指定 1mm 単位)
				15 16	8 10	
				18 20 22	10 12	
	30			15 16	8 10	
				18	10 12	
				20 22 24 25	12 16	
	35			18	10 12	
				20 22	12 16	
				24 25 28 30 32	16 20	
	40			20 22	12 16	
				24 25 28 30 32 36	16 20	



Order

Catalog No.	D	L	S	P	M	G
KOPB	16	300	S15	P12	M6	
KOPBS	25	600	S35	P20	M12	G40



Option

オプションコード	仕様
YR	高周波焼入れ部の先端に焼入れ無し部を設けます(下図 YR 部)。



Order

KOPB 16 - 300 - S15 - P12 - M6 - YR



●YR 部長さ

D	φ8~φ16	φ20	φ25	φ30~
YR	30	40	50	60



ご注文方法が変更になりました。

(旧) KOPB16-300- 15- 12-K6

(新) KOPB16-300-S15-P12-M6