

パネル先行押えピン

エコノミータイプ

PANEL STABILIZER PIN

PSPCN (先端無加工)
 PSPCS (先端球面加工)
 PSPCU (先端ウレタン)

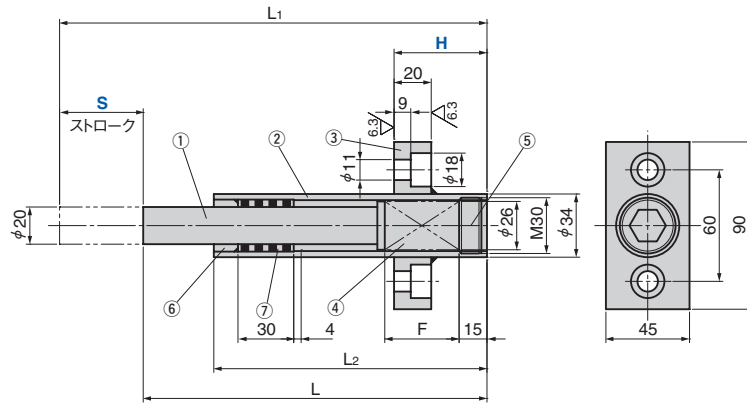

PSPCN

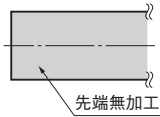

PSPCS

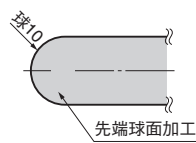

PSPCU

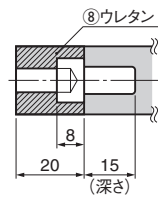

Catalog No.	ストローク S	H 指定1mm単位	荷重 N (kgf)		L	L1	L2	F
			初圧	終圧				
PSPCN	40	$20 \leq H \leq L_2$	44.8 (4.6)	403.1	230	270	147	45
	50		36.7 (3.8)		250	300	167	55
PSPCS	60		16.1 (1.7)	(41.1)	270	330	185	63
PSPCU	70		26.9 (2.8)		290	360	207	75



Catalog No. **PSPCN** S **50** - H **50**

PCU (ウレタンアタッチメント)

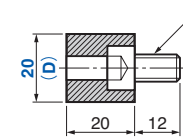

Catalog No.	D
PCU	20



Catalog No. **PCU** D **20**

No.	名称	数	材質/備考
1	先行ピン	1	Steel
2	ホルダ	1	Steel
3	フランジ	1	Steel
4	スプリング	1	—
5	スクリーブプラグ	1	M30
6	ストッパ	1	Steel
7	ガイドブッシュ	1	SOB
8	ウレタンアタッチメント	1	—