

# Slide Plate

EUROPEAN STANDARD

VSM (SP2)

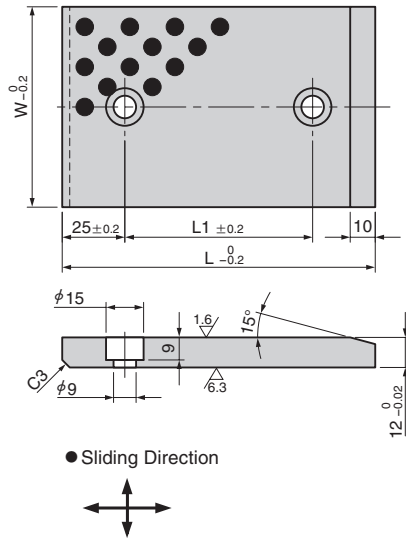
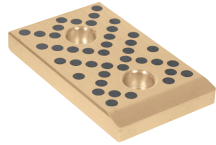

(Material) SO#50SP2

VSM (ST)

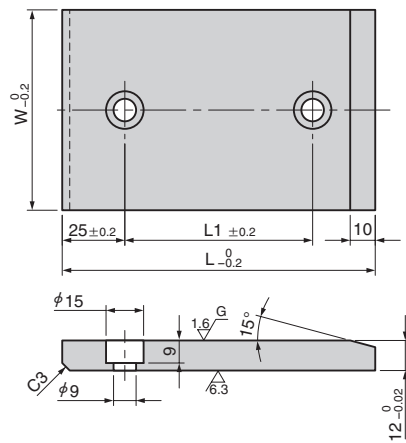

(Material) 1.2379(SKD11)  
HRC060 or more

Catalog No.		W	L	L1
Bronze with Graphite Type	Steel ST			
VSM-11-SP2	VSM-41-ST02	30	80	30
VSM-12-SP2	VSM-42-ST02		100	50
VSM-13-SP2	VSM-43-ST02		125	75
VSM-14-SP2	VSM-44-ST02		160	110
VSM-15-SP2	VSM-45-ST02		200	150
VSM-16-SP2	VSM-46-ST02	40	80	30
VSM-17-SP2	VSM-47-ST02		100	50
VSM-18-SP2	VSM-48-ST02		125	75
VSM-19-SP2	VSM-49-ST02		160	110
VSM-20-SP2	VSM-50-ST02		200	150
VSM-21-SP2	VSM-51-ST02	50	80	30
VSM-22-SP2	VSM-52-ST02		100	50
VSM-23-SP2	VSM-53-ST02		125	75
VSM-24-SP2	VSM-54-ST02		160	110
VSM-25-SP2	VSM-55-ST02		200	150
VSM-26-SP2	VSM-56-ST02	60	80	30
VSM-27-SP2	VSM-57-ST02		100	50
VSM-28-SP2	VSM-58-ST02		125	75
VSM-29-SP2	VSM-59-ST02		160	110
VSM-30-SP2	VSM-60-ST02		200	150
VSM-31-SP2	VSM-61-ST02	80	80	30
VSM-32-SP2	VSM-62-ST02		100	50
VSM-33-SP2	VSM-63-ST02		125	75
VSM-34-SP2	VSM-64-ST02		160	110
VSM-35-SP2	VSM-65-ST02		200	150



Order

Catalog No.

VSM-33-SP2  
VSM-63-ST02